



NEW! 25-YEAR LINEAR
PERFORMANCE AND
PRODUCT WARRANTY
EXTENDED TO 5 YEARS*

Length	1675 mm
Width	682 mm
Height	31 mm
Frame	Aluminium
Weight	13 kg

Sunmodule⁺

SW 145/150/155 Compact mono black

German quality standards

Fully-automated production lines and seamless monitoring of the process and material ensure the quality that the company sets as its benchmark for its sites worldwide.

Outstanding products

In Photon test laboratory's endurance test SolarWorld's modules occupied first place in 2008 and in 2009.

SolarWorld Plus-sorting

Plus-sorting guarantees the highest system efficiency. Only modules that achieve the designated nominal performance or greater in performance tests are despatched.

25 years linear performance guarantee*

SolarWorld guarantees a maximum degeneration in performance of 0.7% p.a. for more than 25 years – a clear additional benefit compared with the conventional two-stage industry guarantees. In addition, there is a product warranty that covers 5 years.

*In accordance with the applicable SolarWorld service certificate at purchase
www.solarworld-global.com/service-certificate



We turn sunlight into power.

PERFORMANCE UNDER STANDARD TEST CONDITIONS (STC)*

		SW 145	SW 150	SW 155
Maximum power	P_{max}	145 Wp	150 Wp	155 Wp
Open circuit voltage	U_{oc}	24,8 V	24,9 V	25,0 V
Maximum power point voltage	U_{mpp}	19,5 V	19,8 V	20,1 V
Short circuit current	I_{sc}	8,09 A	8,13 A	8,18 A
Maximum power point current	I_{mpp}	7,45 A	7,59 A	7,72 A

*STC: 1000W/m², 25°C, AM 1.5

PERFORMANCE AT 800 W/m², NOCT, AM 1.5

		SW 145	SW 150	SW 155
Maximum power	P_{max}	104,4 Wp	108,5 Wp	112,6 Wp
Open circuit voltage	U_{oc}	22,3 V	22,5 V	22,7 V
Maximum power point voltage	U_{mpp}	17,4 V	17,9 V	18,3 V
Short circuit current	I_{sc}	6,54 A	6,56 A	6,58 A
Maximum power point current	I_{mpp}	6,00 A	6,07 A	6,14 A

Minor reduction in efficiency under partial load conditions at 25°C: at 200W/m², 95% (+/-3%) of the STC efficiency (1000 W/m²) is achieved.

COMPONENT MATERIALS

Cells per module	40
Cell type	Mono crystalline
Cell dimensions	156 mm x 156 mm
Front	tempered glass (EN12150)

SYSTEM INTEGRATION PARAMETERS

Maximum system voltage SC II	1000 V
Maximum reverse current	16 A
Increased snowload acc. to IEC 61215	5,4 kN/m ²
Number of bypass diodes	2

THERMAL CHARACTERISTICS

NOCT	47 °C
TC I_{sc}	0,042 %/K
TC U_{oc}	-0,33 %/K
TC P_{mpp}	-0,45 %/K

ADDITIONAL DATA

Measuring tolerance	+/- 3 %
Junction box	IP65
Connector	MC4
SolarWorld Plus-Sorting ²⁾	$P_{Flash} \geq P_{max}$

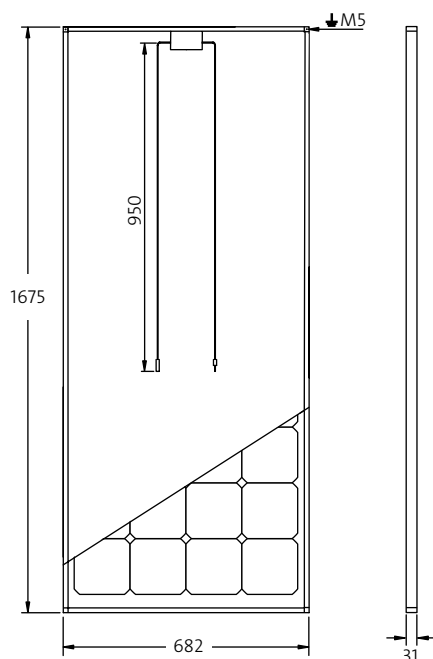

- Qualified, IEC 61215
- Safety tested, IEC 61730
- Periodic Inspection



2) The output identified by SolarWorld (PFlash) is always higher than the nominal output (Pmax) of the module.

3) depending on the market
SolarWorld AG reserves the right to make specification changes without notice. This data sheet complies with the requirements of EN 50380.